

JANUARY 2001

MATHEMATICS

Paper 02 - General Proficiency

2 hours 40 minutes

03 JANUARY 2001 (a.m.)

INSTRUCTIONS TO CANDIDATES

1. Answer ALL questions in Section I, and any TWO in Section II.
2. Begin the answer for each question on a new page.
3. Full marks may not be awarded unless full working or explanation is shown with the answer.
4. Mathematical tables, formulae and graph paper are provided.
5. Silent electronic calculators may be used for this paper.
6. You are advised to use the first 10 minutes of the examination time to read through this paper. Writing may begin during this 10-minute period.

SECTION I

Answer ALL the questions in this section.

All working must be clearly shown.

1. (a) Find the exact value of

$$\frac{4\frac{1}{8} - 3\frac{3}{4}}{1\frac{1}{7}},$$

giving the answer as a fraction in its lowest terms.

(5 marks)

- (b) In a certain country, electricity charges are calculated based on a the following table:

Fixed charge	Charge per kWh used
\$4.00	12 cents

- (i) Calculate the electricity charges for a customer who used 1003 kWh.

There is a government tax of 15% on the electricity charges.

- (ii) Calculate the tax on the customer's electricity charges, giving your answer to the nearest cent.

- (iii) Calculate the total amount paid by the customer.

(6 marks)

Total 11 marks

2. (a) Factorize completely

(i) $a^2 - 9$

(ii) $6ap + 15a - 4p - 10$

(3 marks)

- (b) Simplify

(i) $2y + 3(y - 1)$

(ii) $\frac{m+2}{2} - \frac{m}{3}$

(5 marks)

- (c) Solve the equation

$$\frac{x}{4} + 16 = 2x$$

(2 marks)

- (d) Calculate the values of x for which

$$x - 5 \leq 7 - 2x$$

(2 marks)

Total 12 marks

GO ON TO THE NEXT PAGE

3. (a) In a group of 40 students,
all students study Mathematics
- 28 students study Biology and Mathematics
20 students study Geography and Mathematics
 x students study all three subjects
- (i) Draw a Venn diagram to represent the above information, showing in terms of x , the number of students in each subset.
- (ii) Determine the number of students who study all three subjects. (5 marks)
- (b) Given that $P = \begin{pmatrix} 3 & 1 \\ -2 & 0 \end{pmatrix}$ and $S = \begin{pmatrix} 2 & 1 \\ -1 & -2 \end{pmatrix}$,
find the value of
- (i) $2P - S$
- (ii) S^2 (6 marks)

Total 11 marks

4. (a) (i) Using ruler and compasses only, construct a parallelogram $KLMN$, so that $KL = 8$ cm,
 $LM = 6$ cm and angle $KLM = 135^\circ$.
- (ii) Draw KM . Measure and state its length. (6 marks)
- (b) E is the point $(-2, 5)$ and F is the point $(2, -3)$.
Find, by calculation,
- (i) the coordinates of G , the midpoint of EF
- (ii) the gradient of EF (3 marks)
- (c) Determine the equation of the perpendicular bisector of EF . (3 marks)

Total 12 marks

5. (a) In a box there are n red balls and three times as many black balls.
- (i) Write an expression in n to represent the total number of balls in the box.
Eight balls are removed from the box. There are 20 balls remaining.
- (ii) Write an equation in n to show this.
- (iii) Using your equation, calculate the number of black balls in the box at the start. (5 marks)

- (b) Given that $f(x) = x + 2$, and $g(x) = \frac{3}{x}$,
- calculate $f(-1)$
 - write an expression for $gf(x)$
 - calculate the values of x so that $f(x) = g(x)$. (6 marks)

Total 11 marks**6. An answer sheet is provided for this question.**

- (a) The diagram on the **answer sheet provided** shows a triangle with vertices VAC .
- State the coordinates of V, A and C .

The triangle is translated by the vector $\begin{pmatrix} 5 \\ -2 \end{pmatrix}$.

- Draw the image of triangle VAC . Label it $V'A'C'$.

Triangle $V'A'C'$ is then reflected in the line $y = 2$.

- Draw the image, $V''A''C''$. (8 marks)

- (b) Describe fully a single transformation that would map triangle VAC onto triangle $V''A''C''$. (3 marks)

Total 11 marks

7. The table shows a grouped frequency distribution of the prices paid for lunches by a group of 50 workers.

Price (\$)	Frequency (f)
0 – 4	2
5 – 9	5
10 – 14	12
15 – 19	18
20 – 24	9
25 – 29	3
30 – 34	1

- Calculate an estimate of the mean price paid for lunch. (4 marks)
- Using a scale of 2 cm to represent 5 units on both axes, draw a histogram to represent the distribution of prices. (5 marks)
- Estimate the probability that a worker selected at random would spend at least \$20 on lunch. (2 marks)

Total 11 marks

8.

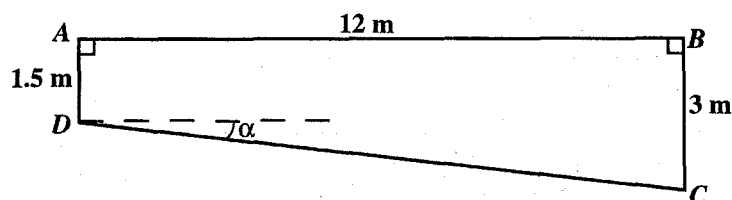

The figure above, **not drawn to scale**, shows the cross-section $ABCD$ of a swimming pool, 12 m long. AB is the horizontal top edge, AD shows the depth at the shallow end and BC the depth at the deep end.

- (a) Calculate, giving the answers correct to 1 decimal place,
- α , the angle that DC makes with the horizontal
 - the length of the sloping edge, DC . (5 marks)
- (b) Given that the pool is 5 m wide, calculate the total surface of the inner walls and the bottom of the pool. (6 marks)

Total 11 marks

SECTION II

Answer **TWO** questions in this section.

RELATIONS AND FUNCTIONS

9. (a) Write $f(x) = 3x^2 - 2x - 4$, in the form
 $f(x) = p(x + q)^2 + r$,
 where p , q and r are constants. (4 marks)
- (b) State (i) whether $f(x)$ has a maximum or minimum value, and write down this value
 (ii) the value of x at which this value occurs. (3 marks)
- (c) Find, correct to 1 decimal place, the values of x that satisfy the equation $3x^2 - 2x - 4 = 0$. (4 marks)
- (d) Sketch the graph of $f(x)$, labelling clearly the coordinates of the maximum or minimum point and the points of intersection with the axes. (4 marks)

Total 15 marks

10.

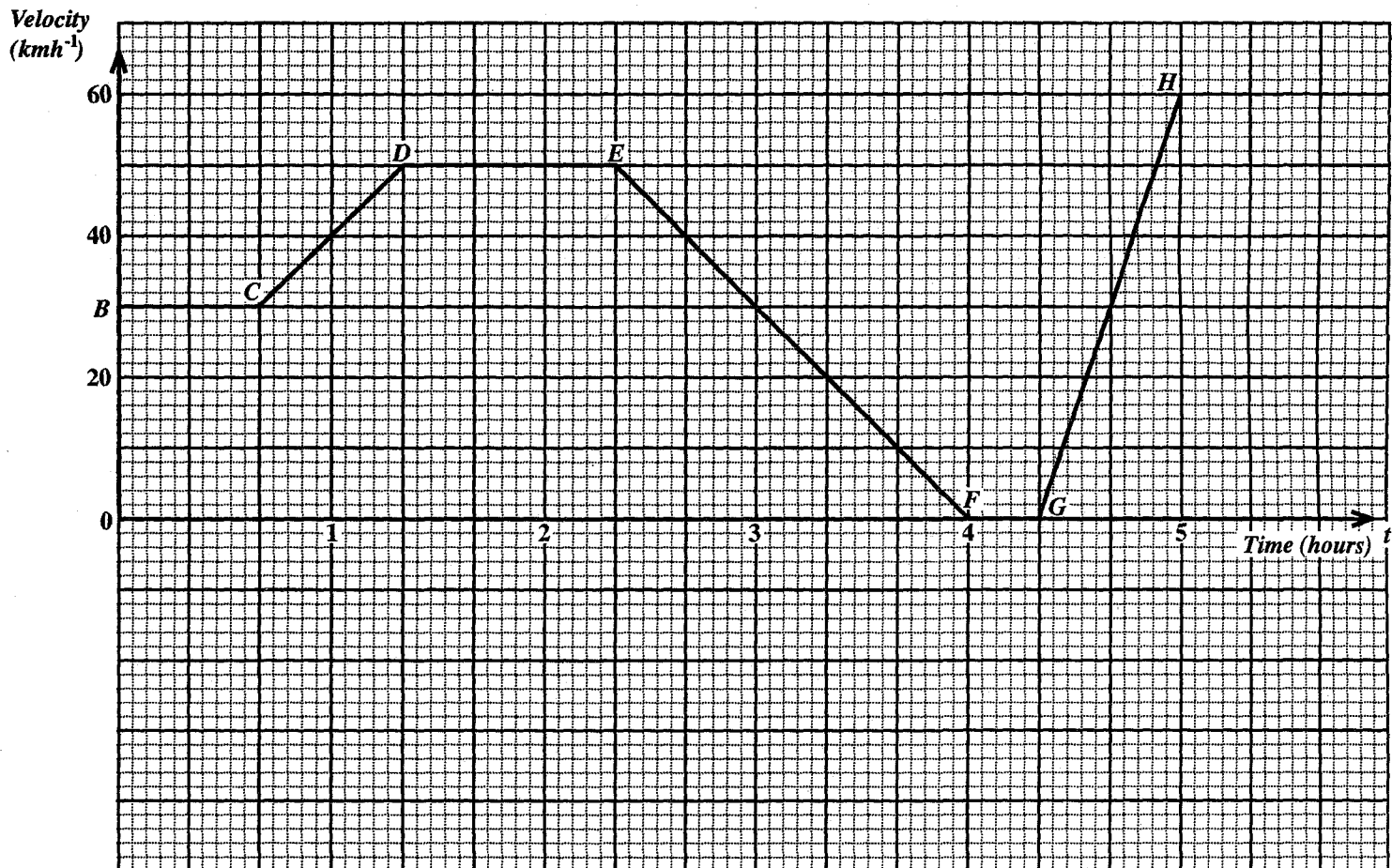

The graph above represents the motion of a car during part of a journey for a period of 5 hours. Using the graph,

- (a) describe, fully the movements of the car, including the relevant time intervals,
- from C to D
 - from D to E
 - from F to G
- (5 marks)
- (b) when $t = 3$, determine
- the speed of the car in kmh^{-1}
 - the acceleration of the car in $\text{kmh}^{-1}/\text{min}$, showing all calculations necessary.
- (3 marks)
- (c) calculate the distance travelled from $t = 1$ to $t = 4$. (5 marks)
- (d) show that the distance covered in the first 40 minutes and in the last 40 minutes are equal. (2 marks)

Total 15 marks

GO ON TO THE NEXT PAGE

GEOMETRY AND TRIGONOMETRY

11.

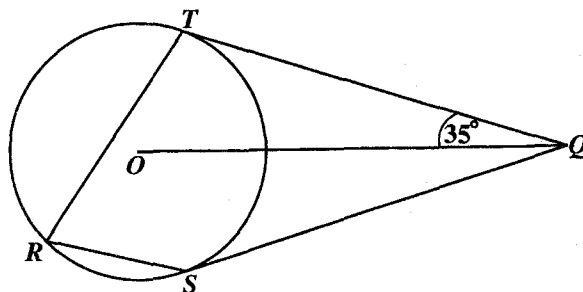

- (a) Given a circle, centre O and radius 5 cm. Tangents QT and QS are drawn from a point Q to touch the circle at T and at S . Angle $OQT = 35^\circ$.

The arc TS subtends the angle TRS at the circumference.

Calculate the size of angle TRS .

[Give reasons for all statements made.]

(6 marks)

- (b) [Take the radius of the earth to be 6370 km and $\pi = 3.14$]

The position of two towns are $H(40^\circ \text{ S}, 60^\circ \text{ E})$ and $J(40^\circ \text{ S}, 30^\circ \text{ W})$.

- (i) Calculate, correct to 3 significant figures, the distance HJ along the circle of latitude.

Another town K is the same distance north of H as J is west of H .

- (ii) Determine the coordinates of K .

(9 marks)

Total 15 marks

12.

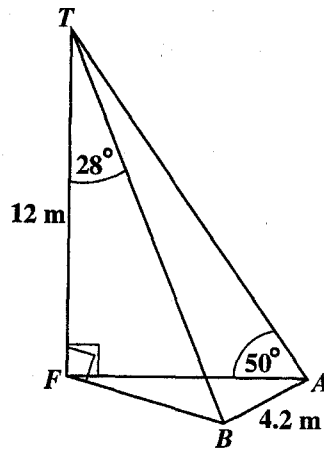

The diagram above, **not drawn to scale**, shows a pole TF , 12 m high, standing on level ground. The points A , F and B lie in the same horizontal plane.

$AB = 4.2\text{ m}$, $\hat{BTF} = 28^\circ$ and $\hat{TAF} = 50^\circ$. \hat{TFB} and \hat{TFA} are right angles.

(a) Calculate

- (i) the lengths of FB and FA , giving your answers to 3 significant figures
- (ii) the size of \hat{AFB} , to the nearest degree
- (iii) the bearing of B from F . (9 marks)

(b) Given that the area of triangle $BTA = 28.1\text{ m}^2$ and $AT = 15.7\text{ m}$, calculate the size of \hat{BTA} . (6 marks)

Total 15 marks

VECTORS AND MATRICES

13. The coordinates of the points P , R , S and T are $(2, 2)$, $(5, 4)$, $(3, 1)$ and $(0, -1)$ respectively.
- (a) Write, in the form $\begin{pmatrix} x \\ y \end{pmatrix}$, the position vectors of P , R , S and T . (2 marks)
- (b) Determine, in the form $\begin{pmatrix} x \\ y \end{pmatrix}$, the vectors
- (i) \vec{PR}
- (ii) \vec{RS}
- (iii) \vec{ST} . (4 marks)
- (c) Show, by a vector method, that
- (i) the figure $PRST$ is a parallelogram, and
- (ii) the parallelogram is a rhombus. (5 marks)
- (d) N is the point on the line segment TR such that $TN : NR = 1 : 4$. Determine the position vector of N . (4 marks)

Total 15 marks

14. (a) (i) Write the matrix M_x that represents reflection in the x -axis.
- (ii) Write the matrix M_y that represents reflection in the y -axis.
- (iii) Determine the single matrix Q that represents reflection in the x -axis followed by reflection in the y -axis.
- (iv) Describe fully the transformation represented by Q . (7 marks)
- (b) The coordinates of ΔLCD are $L(6, 13)$, $C(2, 5)$ and $D(6, 3)$ respectively. $\Delta L'C'D'$ is the image of ΔLCD under a transformation H . The coordinates of $\Delta L'C'D'$ are $L'(-13, 6)$, $C'(-5, 2)$ and $D'(-3, 6)$ respectively.
- (i) Describe fully the transformation H .
- (ii) Write down the matrix H that represents the transformation.
- (iii) Determine the matrix that would transform $\Delta L'C'D'$ back to ΔLCD (8 marks)

Total 15 marks

END OF TEST

Answer Sheet for question 6

Jan 2001

(To be attached in the booklet with your other answers)

Candidate Registration Number: _____

Question Number: _____

